

E-M-HF7-V1_27

Document code

Rotronic AG
Bassersdorf, Switzerland

Unit

HygroFlex HF7 Humidity Temperature Transmitters: User Guide

Instruction Manual

Document Type

Document title

Page 1 of 27

HygroFlex HF7 Humidity Temperature Transmitters

User Guide



E-M-HF7-V1_27	Rotronic AG Bassersdorf, Switzerland
Document code	Unit
HygroFlex HF7 Humidity Temperature Transmitters: User Guide	Instruction Manual
	Document Type
Document title	Page 2 of 27

Table of contents

1	Overview	3
2	Mechanical configurations and dimensions	4
3	General description.....	5
3.1	Power supply	5
3.2	Measured parameters	5
3.3	Calculated parameters	5
3.4	Analog output signals	6
3.5	Display option	7
3.6	Service connector	7
3.7	Sensor protection (dust filter).....	7
4	User configurable settings and functions	8
4.1	Function overview.....	8
4.2	Factory default settings	10
5	Mechanical installation	11
5.1	General guidelines.....	11
5.2	Enclosure installation (HF7 type N and W).....	12
5.3	Probe installation (HF7 type N, D and A).....	12
6	Electrical installation	13
6.1	General wiring guidelines	13
6.2	Cable grip and cable specifications	14
6.3	Wiring and terminal block diagrams.....	14
7	Operation	18
7.1	Minimum load requirements for the HF73 with voltage outputs	18
7.2	HF72 and HF73 transmitters (analog outputs).....	18
8	Maintenance.....	19
8.1	Service cable	19
8.2	Location of the service connector (mini USB type).....	20
8.3	Periodic calibration check	21
8.4	Cleaning or replacing the dust filter	21
8.5	Validation of the output signals transmission.....	21
9	Firmware updates.....	22
10	Technical data	23
10.1	Specifications	23
10.2	Dew point accuracy	25
11	Accessories	26
12	Supporting documents	26
13	Document releases	27

E-M-HF7-V1_27 Document code	Rotronic AG Bassersdorf, Switzerland Unit
HygroFlex HF7 Humidity Temperature Transmitters: User Guide Document title	Instruction Manual Document Type
	Page 3 of 27

Applicability:

This manual applies to all instruments of the HF7 series with firmware version 3.0 or higher. Changes to the last digit of the version number reflect minor firmware changes that do not affect the manner in which the instrument should be operated.

1 Overview

The HF7 transmitter series are designed for fixed installation in industrial applications. The HF7 measures relative humidity and temperature and can be configured to calculate the dew or frost point. Depending on the model, the HF7 can measure environments within the range of 0 to 100 %RH and -100 to 150°C (-148 to 302°F). The electronics operating range is limited to -40...85 °C (-40...185 °F) and for units with display -10...60°C (14...140 °F)

Two types of electronic circuits are available:

- HF72: 2-wire, loop powered (4...20 mA current signal)
- HF73: 3-wire (voltage or current signal).

Both circuit types provide linear analog outputs signals for transmission over a length of cable to a remote display, recorder, controller or data processing unit and can be used to measure humidity only, temperature only or both parameters.

The HF7 features well proven sensors and a robust housing. Digital signal processing ensures consistent product performance and also facilitates the task of field maintenance with features such as potentiometer free – digital calibration.

Based on the ROTRONIC AirChip 3000 digital technology the HF7 series offers the following functions:

- User configurable settings
- Calculation of the dew or frost point
- Humidity temperature calibration and adjustment
- Simulator mode
- Automatic humidity sensor test and drift compensation
- Fail safe mode
- Data recording

The ability for the user to easily update the AirChip 3000 firmware means that instruments of the HF7 series can be kept up-to-date regarding any future functionality improvement.

E-M-HF7-V1_27	Rotronic AG Bassersdorf, Switzerland
Document code	Unit
HygroFlex HF7 Humidity Temperature Transmitters: User Guide	Instruction Manual
	Document Type
Document title	Page 4 of 27

2 Mechanical configurations and dimensions

Type W: Wall Mount

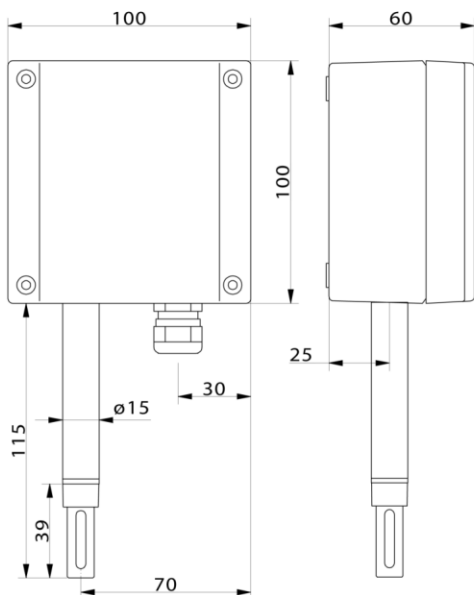

Type N: Cable Probe

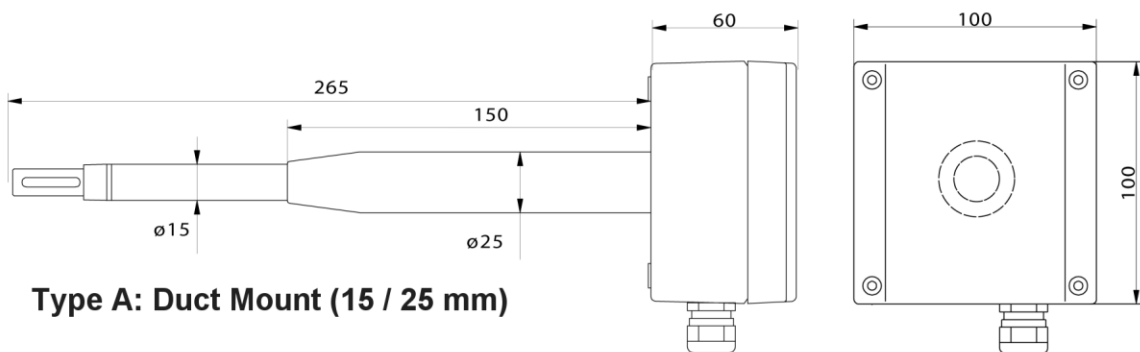
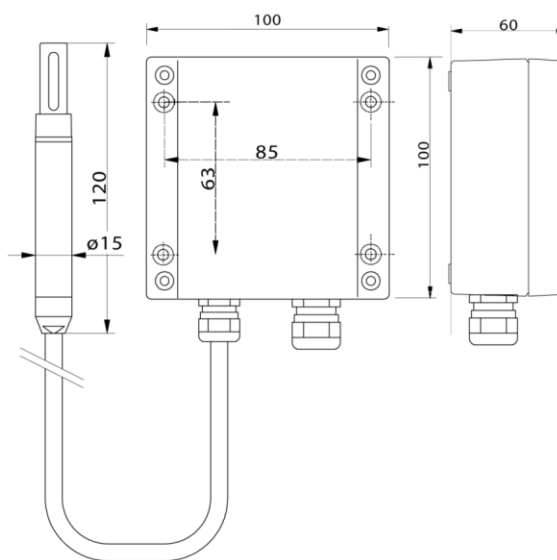

Type A: Duct Mount (15 / 25 mm)

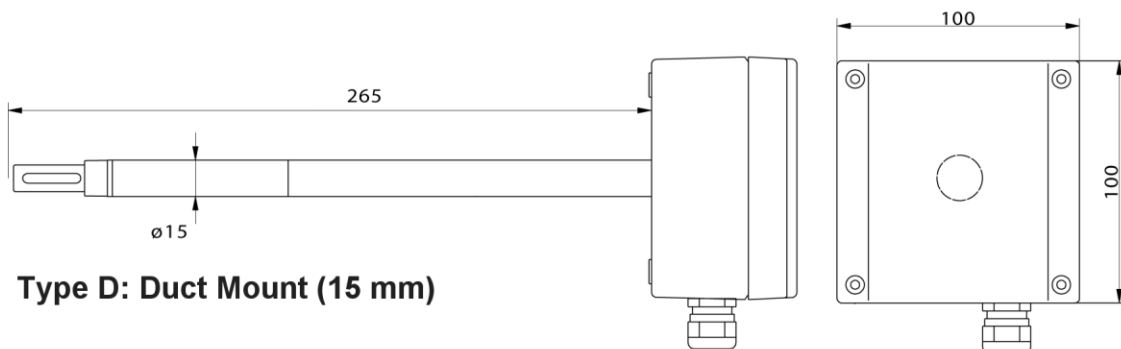

Type D: Duct Mount (15 mm)

Dimensions in mm

E-M-HF7-V1_27 Document code	Rotronic AG Bassersdorf, Switzerland Unit
HygroFlex HF7 Humidity Temperature Transmitters: User Guide Document title	Instruction Manual Document Type Page 5 of 27

3 General description

3.1 Power supply

Depending on the circuit type, the HF7 requires the following power supply:

- a) **HF72** (2-wire, loop powered): 10...28 VDC - depending on the load connected to the output(s). The minimum supply voltage can be determined as follows:

$$V_{\min} = 10 \text{ V} + (0.02 \times \text{Load}^*) \quad * \text{Load resistance in ohms.}$$

For the maximum load of 500 Ω , the minimum supply voltage is $10 + (0.02 \times 500) = 20$ VDC. With both output circuits closed, the maximum current consumption is 40 mA.

- b) **HF73** (3-wire with analog outputs): 18 to 40 VDC (see note below) or 13 to 28 VAC. With both output circuits closed, the maximum current consumption is 100 mA for DC powered devices and 250 mA for AC powered devices.

Note: depending on the type of output signal, the HF73 will operate with the following minimum voltage

0...1 V outputs:	6 VDC or 5 VAC
0...5 V outputs:	10 VDC or 8 VAC
0...10 V outputs:	18 VDC or 13 VAC
0...20 mA or 4 ...20 mA outputs:	6 VDC or 5 VAC with 0 Ω load 18 VDC or 13 VAC with 500 Ω load

3.2 Measured parameters

The HF7 measures relative humidity with a ROTRONIC Hygromer® IN1 capacitive sensor and temperature with a Pt100 RTD.

3.3 Calculated parameters

Using the ROTRONIC HW4 software, the HF7 can be configured by the user to calculate either the dew point or the frost point.

E-M-HF7-V1_27 Document code	Rotronic AG Bassersdorf, Switzerland Unit
HygroFlex HF7 Humidity Temperature Transmitters: User Guide Document title	Instruction Manual Document Type Page 6 of 27

3.4 Analog output signals

HF72 and HF73

With the ROTRONIC HW4 software any of the two analog output signals can be made to correspond to one of the following:

- Relative humidity
- Temperature
- Dew or frost point

Any output can also be disabled.

The scale of each analog output can be set within the numerical limits of -999.99 and 9999.99.

The D/A converters used to generate the analog output signals feature a 16-bit resolution.

The D/A converters used to generate the analog output signals feature a 16-bit resolution and exhibit a small positive offset at the bottom of the signal range as indicated below:

Signal type	Maximum offset at range bottom
0...1 V	10 mV
0...5 V	50 mV
0...10 V	100 mV
0...20 mA	0.2 mA
4...20 mA	No offset

HF73

The ROTRONIC HW4 software allows changing the type of output signal to one of the following: 0...20 mA, 4...20 mA, 0...1V, 0...5V or 0...10V. Both output signals are automatically configured with the same signal type. No calibration or adjustment is required after changing the type of output signal.

In the case of voltage output signals, load requirements apply to the external device or circuit connected to the HF73 transmitter. These requirements are defined in the "Operation" chapter

E-M-HF7-V1_27 Document code	Rotronic AG Bassersdorf, Switzerland Unit
HygroFlex HF7 Humidity Temperature Transmitters: User Guide Document title	Instruction Manual Document Type
	Page 7 of 27

3.5 Display option

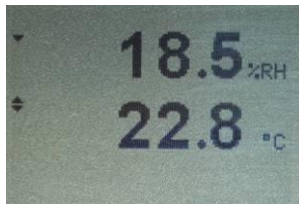

The upper line of the display corresponds to relative humidity or dew / frost point and the bottom line corresponds to temperature.

The display can be configured to show a trend indicator on each line:

- ▲: increasing value
- ▼: decreasing value

In the event of an alarm the display shows the symbol [!] to the right of the value. For instructions see the following HW4 manual: **E-M-HW4v3-F2-007**.

The display option for the HF73 has a backlight. The display option for the HF72 does not have a backlight.

3.6 Service connector

The service connector is a UART digital interface (Universal Asynchronous Receiver Transmitter) with a mini-USB type connector. This allows connecting the HF7 either to a PC running the ROTRONIC HW4 software or to a probe input of another instrument that is compatible with the HygroClip 2 (HC2) probes. In both cases a service cable is required. See "Maintenance" for the location of the service connector and for the type of service cable to be used.

- Connecting the HF7 to a PC is used to configure the HF7, gain access to the HF7 functions such as humidity and temperature adjustment, read data from the HF7 on the PC and update the AirChip 3000 firmware.
- Connecting the HF7 to the probe input of another instrument is useful only when the other instrument has its own display and keypad, and has an internal menu equivalent to the menu of the HP23 hand-held calibrator. The connection allows showing the data measured by the HF7 on the other instrument display and also allows using the other instrument internal menu to do for example a humidity and temperature adjustment of the HF7.

3.7 Sensor protection (dust filter)

A dust filter is required to protect the sensors against dust particles and high air velocity. The probe of the HF7 is equipped with a with a metal filter base mod. NSP-ME. The filter cartridge must be ordered separately (see Accessories 11.5). Filter cartridge mod. SP-M15 is suitable for most applications.

E-M-HF7-V1_27 Document code	Rotronic AG Bassersdorf, Switzerland Unit
HygroFlex HF7 Humidity Temperature Transmitters: User Guide Document title	Instruction Manual Document Type Page 8 of 27

4 User configurable settings and functions

The HF7 ships configured as specified on the customer order. The analog outputs can be used just as with any conventional humidity and temperature transmitter and most users will never need to use the HF7 configurable settings and functions.

Making use of the HF7 configurable settings and functions is entirely up to the user and the appropriate settings depend on the user application. We have provided below a short description of the HF7 functions and also indicated the factory default settings.

4.1 Function overview

MEASUREMENT ACCURACY AND RELIABILITY	
AirChip 3000 Functions	Description
▶ Humidity / temperature adjustment	<ul style="list-style-type: none"> ○ 1-point or multi-point humidity calibration or adjustment ○ 1-point or 2-point temperature calibration or adjustment ○ Generate a time stamp for calibrations and adjustments ○ Retain and view last adjustment date and adjustment values ○ Generate calibration and adjustment protocols
▶ Automatic humidity sensor test and optional drift compensation	<p>Tests the humidity sensor for drift caused by contaminants and can be used to automatically apply a correction. The test is automatically carried out at regular intervals of time. Can be configured, enabled, or disabled</p> <p>The humidity sensor status can be verified either with the HW4 software or with the instrument display (if available) and is shown as Good, SQ-tuned (corrected for drift) or Bad (defective)</p>
▶ Data recording	<p>The data recording function differs from a true data logging function in the sense that the AirChip 3000 does not time stamp the data. This data recording function can be used to investigate events such as a sensor malfunction as well as to retrieve data that would otherwise be lost</p> <ul style="list-style-type: none"> ○ Start or stop data recording - up to 2000 value pairs (%RH and temperature). Starting a recording session erases all previously recorded data ○ The recording mode and log interval can be specified ○ When the device is powered off, the recording session is paused but not ended. As long as the recording session has not been ended, the device automatically resumes recording data when powered up again ○ The recorded data can be downloaded to a PC with the HW4 software, time stamped and viewed

E-M-HF7-V1_27 Document code	Rotronic AG Bassersdorf, Switzerland Unit
HygroFlex HF7 Humidity Temperature Transmitters: User Guide Document title	Instruction Manual Document Type Page 9 of 27

MEASUREMENT LOOP VALIDATION

AirChip 3000 Functions	Description
▶ Simulator mode	Used to make the HF7 generate fixed values for the humidity, temperature and calculated parameter. Can be configured, enabled or disabled

DEVICE SAFEGUARDS

AirChip 3000 Functions	Description
▶ Device write protection	Used to protect the HF7 with a password to prevent unauthorized digital access by a digital user. Can be configured, enabled or disabled

PROCESS PROTECTION / PROTECTION OF OTHER DEVICES

AirChip 3000 Functions	Description
▶ Limit humidity output to 100 %RH	Used to prevent the humidity signal from exceeding 100 %RH when condensation forms on the sensor. Can be enabled or disabled
▶ Out-of-limit value alarm	Used to specify the normal range for humidity, temperature and the calculated parameter depending on the user application. Can be configured, enabled or disabled Out-of-limit values trigger a digital alarm which can be also be seen on the optional display
▶ Bad sensor alarm	Built-in function. Cannot be disabled A bad humidity or temperature sensor triggers a digital alarm which can be also be seen on the optional display
▶ Fail safe mode	Used to specify a "safe" fixed value for humidity and for temperature in the event of a sensor failure. Can be configured, enabled or disabled

E-M-HF7-V1_27 Document code	Rotronic AG Bassersdorf, Switzerland Unit
HygroFlex HF7 Humidity Temperature Transmitters: User Guide Document title	Instruction Manual Document Type Page 10 of 27

4.2 Factory default settings

Configuration of the HF7 by the user and access to its functions requires a PC with the ROTRONIC HW4 software (version 2.1.1 or higher) installed. Service cable AC3006 or AC3009 is used to connect the HF7 service connector to a USB port of the PC (see Maintenance > Service Cable).

Configurable Settings	Applicability	Factory default
Unit system (Metric or English)	HF72, HF73	As per ordering code
Analog signal type (4...20 mA or other)	HF73	As per ordering code
Psychrometric calculation	HF72, HF73	As per ordering code
Output 1 parameter, scale and unit	HF72, HF73	As per ordering code (%RH or DP)
Output 2 parameter, scale and unit	HF72, HF73	Temperature, unit as per ordering code

Functions	Applicability	Factory default
Humidity / temperature adjustment	HF72, HF73	
Device write protection	HF72, HF73	Disabled
Menu access from keypad	HF72, HF73	Enabled
Limit humidity output to 100 %RH	HF72, HF73	Enabled
Out-of-limit value digital / display alarm	HF72, HF73	Disabled
Data recording	HF72, HF73	Enabled (loop mode – 10 min. interval)
Automatic humidity sensor test	HF72, HF73	Disabled
Humidity sensor drift compensation	HF72, HF73	Disabled
Fail safe mode	HF72, HF73	Disabled
Simulator mode	HF72, HF73	Disabled

- For a detailed description of all AirChip 3000 / HF7 main functions see document **E-T-AC3000-DF-V1**
- Instructions regarding the configuration of the HF7 and access to its functions are provided in the following manuals:
E-M-HW4v3-Main
E-M-HW4v3-F2-007
E-M-HW4v3-DR-001
E-M-HW4v3-A2-001
- The factory default setting for dew / frost point calculation is frost point below freezing

E-M-HF7-V1_27 Document code	Rotronic AG Bassersdorf, Switzerland Unit
HygroFlex HF7 Humidity Temperature Transmitters: User Guide Document title	Instruction Manual Document Type Page 11 of 27

5 Mechanical installation

5.1 General guidelines

Relative humidity is extremely dependent on temperature. Proper measurement of relative humidity requires that the probe and its sensors be at exactly the temperature of the environment to be measured. Because of this, the location where you choose to install the probe can have a significant effect on the performance of the instrument. The following guidelines should guarantee good instrument performance:

- Select a representative location:** install the probe where humidity, temperature and pressure conditions are representative of the environment to be measured.
- Provide good air movement at the probe:** air velocity of at least 200 ft/ minute (1 meter/second) facilitates adaptation of the probe to changing temperature.
- Avoid the following:** (1) Close proximity of the probe to a heating element, a cooling coil, a cold or hot wall, direct exposure to sun rays, etc. (2) Close proximity of the probe to a steam injector, humidifier, direct exposure to precipitation, etc. (3) Unstable pressure conditions resulting from excessive air turbulence.
- Immerse as much of the probe as possible in the environment to be measured.**
HF7 type N with 120 mm probe length: to avoid measurement errors caused by temperature gradients fully immerse the probe barrel in the environment to be measured
- Prevent the accumulation of condensation water at the level of the sensor leads.** Install the probe so that the probe tip is looking downward. If this is not possible, install the probe horizontally.

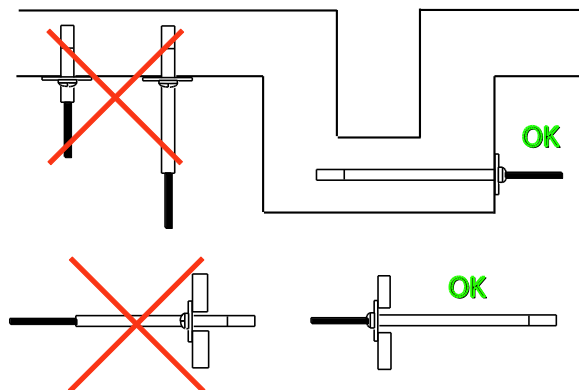

E-M-HF7-V1_27	Rotronic AG Bassersdorf, Switzerland
Document code	Unit
HygroFlex HF7 Humidity Temperature Transmitters: User Guide	Instruction Manual
	Document Type
Document title	Page 12 of 27

5.2 Enclosure installation (HF7 type N and W)

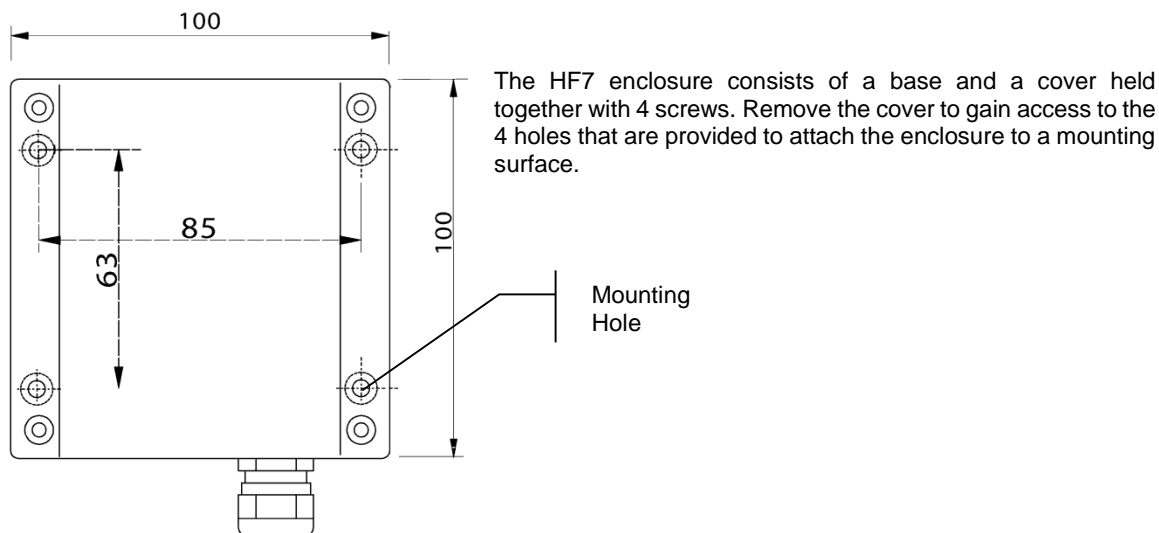

5.3 Probe installation (HF7 type N, D and A)



Type N and D: use parts **AC1303-M** (compression fitting) and **AC1305** (flange) to hold and seal the probe when mounted through a wall (see Accessories).

Type A: use parts **AC1304-M** (compression fitting) and **AC1306** (flange) to hold and seal the probe when mounted through a wall (see Accessories).

- The enclosure of the HF7 type D and A does not require any additional support.

E-M-HF7-V1_27 Document code	Rotronic AG Bassersdorf, Switzerland Unit
HygroFlex HF7 Humidity Temperature Transmitters: User Guide Document title	Instruction Manual Document Type Page 13 of 27

6 Electrical installation

6.1 General wiring guidelines

Power supply wiring

Heavy machinery and instrumentation should not share the same power supply wiring. If this cannot be avoided, noise filters and surge protectors should be used. Most UPS devices have those features already integrated.

General guidelines for signal cables

The following guidelines are derived from European Standard EN 50170 for the transmission of signals by copper wires. When planning an installation, the rules provided by EN 50170 should be followed under consideration of local circumstances to determine the position of machines and equipment.

All ROTRONIC products are tested for Electromagnetic Compatibility according to EMC Directive 2004/106/EG and following European standards:

- EN 61000-6-1: 2001, EN 61000-6-2: 2005
- EN 61000-6-3: 2005, EN 61000-6-4: 2001 + A11

Whenever the level of electromagnetic interference is expected to be high, both the instruments and signal cables should be placed as far away as possible from the source of interference.

In general, signal cables should be installed in bundles or channels / conduits, separate from other cables as indicated in the table below:

<ul style="list-style-type: none"> • Bus signals such as RS485 • Data signals for PCs, printers etc. • shielded analog inputs • unshielded direct current (<= 60V) • shielded process signals (<= 25 V) • unshielded alternate current (<= 25V) • coaxial cables for CRT monitors 	in common bundles or channels / conduits
<ul style="list-style-type: none"> • direct current from 60 V to 400 V (unshielded) • alternate current from 25V to 400 V (unshielded) 	in separated bundles or channels / conduits, without minimum distance
<ul style="list-style-type: none"> • direct and alternate current > 400 V (unshielded) • Telephone lines • lines leading into EX-rated areas 	in separated bundles or channels / conduits, without minimum distance

Lightning protection

Cabling in areas with a risk of lightning requires a lightning protection. For cabling underground in between buildings, we recommend the use of special fiber optic cables. If this is not possible, use copper cables that are suitable for underground installation.

6.2 Cable grip and cable specifications

The HF7 is supplied either with one M16 sealing cable grip or with a ½" conduit adapter. The M16 cable grip provides effective sealing only with cables having the proper outside diameter. Preferably, use a cable with an outside diameter of 6 to 7 mm (0.236 to 0.275 inch) with 18 AWG wires.

6.3 Wiring and terminal block diagrams

6.3.1 HF72: 2-wire, loop powered transmitter

Electrical diagram

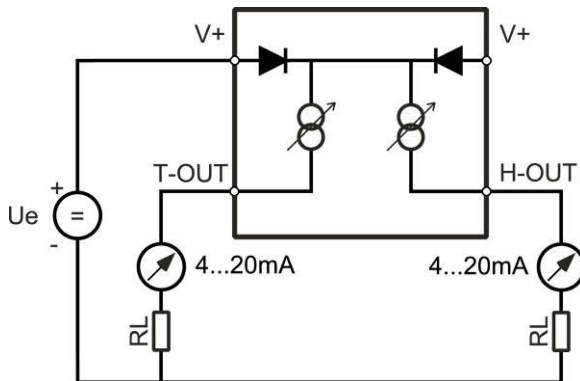

The maximum permissible cable length connecting the HF72 to other devices is determined by the total resistance resulting from the addition of the cable resistance and that of the devices connected in series with the unit. This resistance should not exceed 500 ohms.

E-M-HF7-V1_27	Rotronic AG Bassersdorf, Switzerland
Document code	Unit
HygroFlex HF7 Humidity Temperature Transmitters: User Guide	Instruction Manual
	Document Type
Document title	Page 15 of 27

Terminal block diagram

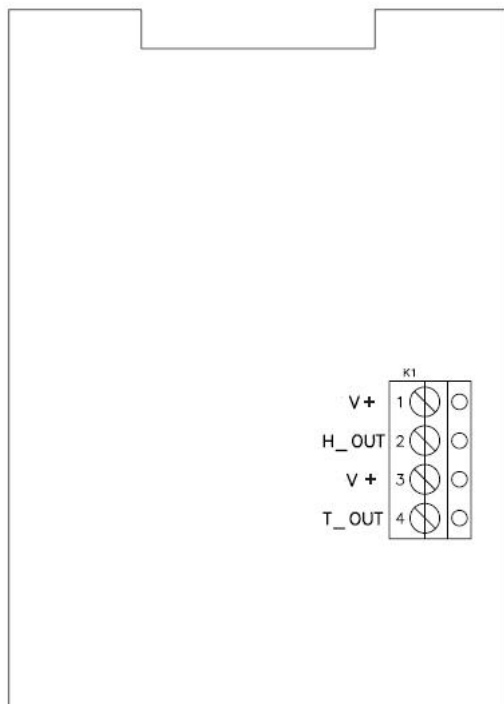

Terminals	Description
K1-1: H+V	Power supply: 10...28 VDC (+)
K1-2: H-OUT	Relative humidity or dew point (+) OUT-1
K1-3: T+V	Power supply: 10...28 VDC (+)
K1-4: T-OUT	Temperature output (+) OUT-2

Important:

The metal housing of the HF7 transmitter must have an electrical grounding to fulfill EMC specifications. The grounding connection is located at the inside of the housing.

Note:

Connect the + of the power supply to only one of the V+ terminals. The two terminals marked H+V and T+V are internally connected.

Measuring humidity or temperature only

Unless configured to measure either humidity only or temperature only, proper operation of the HF72 requires both current loops to be closed. The HF72 can be directly ordered from the factory to measure either humidity or temperature only. When necessary, any unused output of the HF72 can be disabled with the ROTRONIC HW4 software. When the HF72 is configured with one of the two outputs disabled, close only the loop that is being used.

6.3.2 HF73: 3-wire transmitter

Electrical diagram for voltage outputs

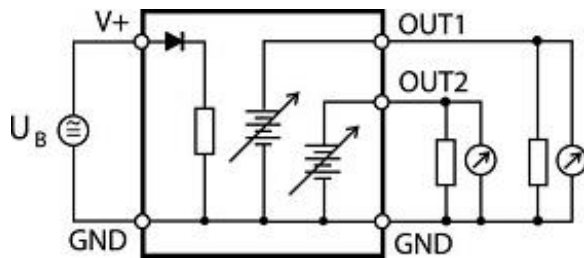

The maximum permissible cable length can be determined under consideration of the voltage drop caused by the current flowing to the devices connected to the unit. The voltage drop in the cable depends both on cable resistance and on the equivalent resistance of the devices connected in parallel to the unit. The total resistance connected to each unit output should be at least 1000 ohms. Cable resistance should not be more than 1/1000 of the load resistance.

Minimum load requirements apply to the external device or circuit connected to the HF7 transmitter. These requirements are defined in the "Operation" chapter

Electrical diagram for current outputs

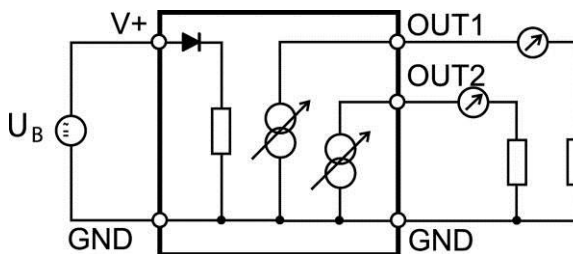

The maximum permissible cable length, connecting the unit to other devices, is determined by the total resistance resulting from the addition of the cable resistance and that of the devices connected in series with the unit. This resistance should not exceed 500 ohms.

E-M-HF7-V1_27	Rotronic AG Bassersdorf, Switzerland
Document code	Unit
HygroFlex HF7 Humidity Temperature Transmitters: User Guide	Instruction Manual
	Document Type
Document title	Page 17 of 27

Terminal block diagram

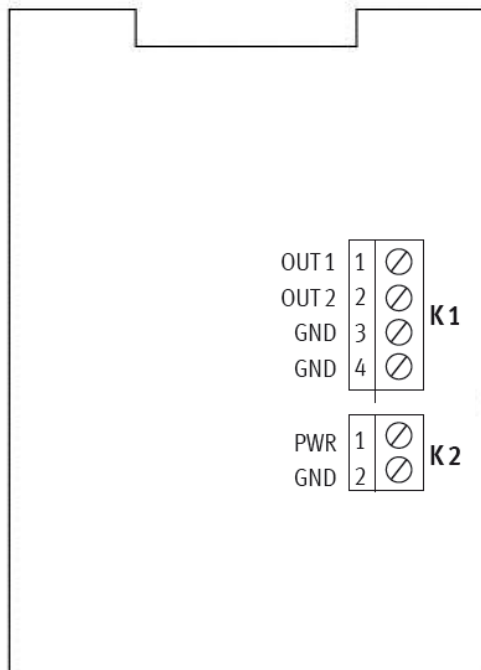

Terminals	Description
K1-1: OUT1	Relative humidity or dew point (+)
K1-2: OUT2	Temperature output (+)
K1-3: GND	Ground (tied with other GND)
K1-4: GND	Ground (tied with other GND)
K2-1: PWR	Power supply: 15...40 VDC (+) or 12...28 VAC (Phase)
K2-2: GND	Power supply (-) or neutral (tied with other GND)

Measuring humidity or temperature only

Operation of the HF73 does not require both current loops to be closed. When using the HF73 to measure either humidity only or temperature only, close only the loop that is being used.

Using the ROTRONIC HW4 software, any unused output of the HF73 can be disabled.

6.3.3 Grounding (all models)

We generally recommend grounding the (-) side of the power supply, especially if the electronics will be subjected to a low humidity environment (35 %RH or less).

7 Operation

7.1 Minimum load requirements for the HF73 with voltage outputs

The following requirements apply to any external device or circuit connected to the HF73 transmitter with voltage outputs:

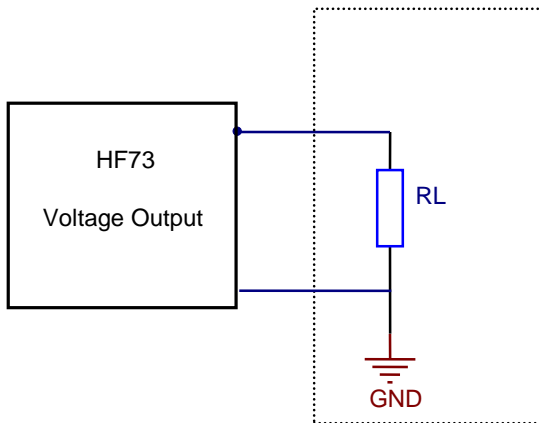

HF73 output signal	Input resistance RL
0...1V	≥1kOhm
0...5V	≥5kOhm
0...10V	≥10kOhm

In the situation where the external device uses an internal pull-up resistor the value of this resistor should meet the requirements shown below. It is also necessary to add a pull-down resistor RL connected to ground in order to be able to read 100% of the range of the HF73 voltage output.

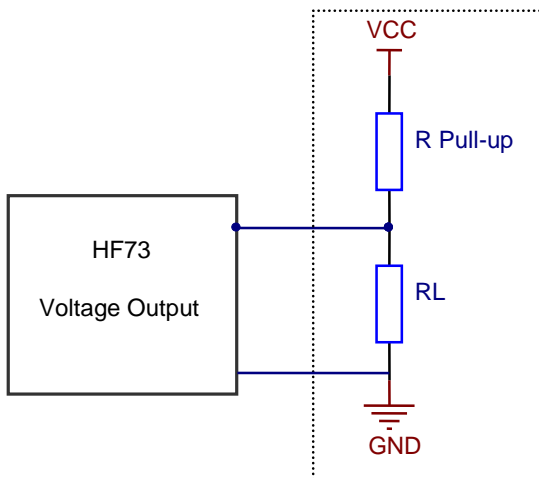

HF73 signal	VCC	R pull-up	RL
0...1V	3.3V	≥ 250 kOhm	1 kOhm

HF73 signal	VCC	R pull-up	RL
0...1V	5.0V	≥ 400 kOhm	1 kOhm
0...5V	5.0V	≥ 400 kOhm	5 kOhm

HF73 signal	VCC	R pull-up	RL
0...1V	10.0V	≥ 1 MOhm	1 kOhm
0...5V	10.0V	≥ 1 MOhm	5 kOhm
0...10V	10.0V	≥ 1 MOhm	10 kOhm

7.2 HF72 and HF73 transmitters (analog outputs)

If so desired, use the HW4 software to configure the HF7. Complete the mechanical and electrical installation and simply power up the HF7.

E-M-HF7-V1_27 <small>Document code</small>	Rotronic AG Bassersdorf, Switzerland <small>Unit</small>
HygroFlex HF7 Humidity Temperature Transmitters: User Guide <small>Document title</small>	<p style="text-align: right;">Instruction Manual</p> <small>Document Type</small> <hr/> Page 19 of 27

8 Maintenance

8.1 Service cable

IMPORTANT:

- Use service cable AC3009 with all 2-wire, loop powered transmitters. This cable powers up the transmitter via the service connector. Do not use any other method for powering the transmitter when using this cable AC3009 as this will create a ground loop and damage the transmitter. For the same reasons do not use cable AC3006 with a 2-wire, loop powered transmitter.
- Use service cable AC3006 with all 3-wire transmitters as well as with digital models. This cable does not provide power to the transmitter and the transmitter should be powered separately when using this cable.
- Both cables AC3006 and AC3009 convert UART (service connector) to USB and are used to connect the transmitter to a USB port of a PC running the ROTRONIC HW4 software. Prior to using any of these cables, the ROTRONIC USB driver must be installed on the PC. Both the driver and the installation instructions (document **E-M-HW4v3-Main**) are located on the HW4 CD.
- As an alternative, cable AC2001 is used to connect the HF7 to a probe input of the HP23 hand-held calibrator. For service purposes, the HP23 offers essentially the same functionality as the HW4 software.

8.2 Location of the service connector (mini USB type)

WARNING: the service connector is a UART interface with a mini-USB connector type. Do not connect the service connector directly to the USB port of a PC or hub.

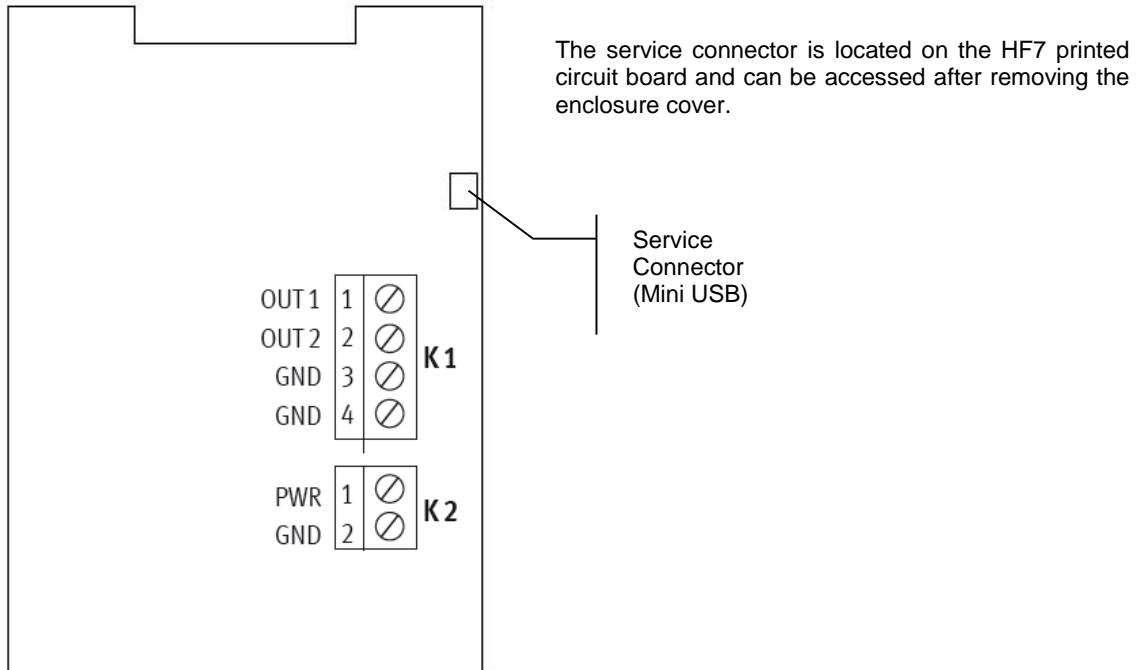

E-M-HF7-V1_27 Document code	Rotronic AG Bassersdorf, Switzerland Unit
HygroFlex HF7 Humidity Temperature Transmitters: User Guide Document title	Instruction Manual Document Type
	Page 21 of 27

8.3 Periodic calibration check

Both the Pt 100 RTD temperature sensor and associated electronics are very stable and should not require any calibration after the initial factory adjustment.

Long term stability of the ROTRONIC Hygromer humidity sensor is typically better than 1 %RH per year. For maximum accuracy, calibration of the HF7 should be verified every 6 to 12 months. Applications where the HF7 is exposed to significant pollution may require more frequent verifications.

Procedure for adjusting the HF7 with the ROTRONIC HW4 software:

- Use the appropriate model of service cable (see Maintenance > Service Cable) to connect the service connector of the HF7 to a USB port of a PC with the HW4 software installed. Note that the ROTRONIC USB driver must be installed on the PC as explained in the HW4 manual **E-M-HW4v3-Main**.
- Start HW4 on the PC and search for the HF7 (HW4 Main Menu Bar > Devices and Groups > Search for USB Masters).
- After finding the HF7 with HW4, expand the device tree to see the HF7 functions. Select Probe Adjustment. Instructions for using the ROTRONIC calibration devices and humidity standards are provided in document **E-M-CalBasics**
- For further instructions see HW4 manual **E-M-HW4v3-A2-001**

8.4 Cleaning or replacing the dust filter

Depending on the conditions of measurement, the filter should be checked from time to time. Corroded, discolored or clogged filters should be replaced.

The probe of the HF7 has a removable filter cartridge. Simply replace the cartridge (leave the metal base on the probe).



8.5 Validation of the output signals transmission

If so desired, transmission of the HF7 output signals can be validated by using the simulator function. The HW4 software is required to enable and configure this function. When this function is enabled the HF7 generates fixed digital and analog signals as specified by the user. For instructions see document **E-M-HW4v3-F2-007**

E-M-HF7-V1_27 <small>Document code</small>	Rotronic AG Bassersdorf, Switzerland <small>Unit</small>
HygroFlex HF7 Humidity Temperature Transmitters: User Guide <small>Document title</small>	<div style="text-align: right;"> Instruction Manual <small>Document Type</small> </div> <hr/> <div style="text-align: right;"> Page 22 of 27 </div>

9 Firmware updates

Firmware updates will be available on the ROTRONIC website for downloading. Firmware files are given a name that shows both to which device the file applies and the version number of the firmware. All firmware files have the extension HEX. Procedure for updating the firmware:

- Use the appropriate model of service cable (see Maintenance > Service Cable) to connect the service connector of the HF7 to a USB port of a PC with the ROTRONIC HW4 software installed. Note that the ROTRONIC USB driver must be installed on the PC as explained in the HW4 manual **E-M-HW4v3-Main**.
- Copy the firmware update file from the ROTRONIC website to the PC.
- Start HW4 software on the PC and search for the HF7 (HW4 Main Menu Bar > Devices and Groups > Search for USB Masters).
- After finding the HF7, expand the device tree to see the HF7 functions. Select Device Manager. In the Device Manager menu bar select Tools > Firmware Update. For instructions see document **E-M-HW4v3-F2-007**

E-M-HF7-V1_27 Document code	Rotronic AG Bassersdorf, Switzerland Unit
HygroFlex HF7 Humidity Temperature Transmitters: User Guide Document title	Instruction Manual Document Type Page 23 of 27

10 Technical data

10.1 Specifications

General	HF72	HF73
Device type	Humidity temperature transmitter with analog output signals	
Circuit type	2-wire, loop powered	3-wire
Mechanical configuration types	N, D, A and W	

Power supply and connections	HF72	HF73
Supply voltage (VDD)	10...28 VDC V min = 10 V + (0.02 x Load*) *Load resistance in ohms.	18...40 VDC or 13...28 VAC
Nominal current consumption	2 x 20 mA	<50 mA
Electrical connections	Terminal block and M16 cable grip or ½" conduit adapter	
Polarity protection	Protective diode on V+	

Humidity measurement	HF72	HF73
Sensor	ROTRONIC Hygromer® IN-1	
Measuring range	0...100 %RH	
Measurement accuracy at 23 °C	±1.0 %RH	
Repeatability	0.3 %RH	
Long term stability	<1 %RH / year	
Sensor time constant	Typical 10 sec, 63% of a 35 to 80 %RH step change (1m/sec air flow at sensor)	

Temperature measurement	HF72	HF73
Sensor	Pt100 RTD, IEC 751 1/3 class B	
Measuring range limits	-100...150 °C / -148...302 °F	
Measurement accuracy at 23 °C	±0.2 °C	
Repeatability	0.05 °C	
Long term stability	<0.1 °C / year	
Sensor time constant	Typical 4 sec, 63% of a step change (1m/sec air flow at sensor)	

Calculated parameters	HF72	HF73
Psychrometric calculations	Dew or frost point (user configurable option)	

E-M-HF7-V1_27	Rotronic AG Bassersdorf, Switzerland
Document code	Unit
HygroFlex HF7 Humidity Temperature Transmitters: User Guide	Instruction Manual
	Document Type
Document title	Page 24 of 27

Start-up time and data refresh rate	HF72	HF73
Start-up time	3.4 s (typical)	1.9 s (typical)
Data refresh rate	3.4 s (typical)	1.7 s (typical)

Configurable analog outputs	HF72	HF73
Output 1	Can be made to correspond to any parameter	
Factory default parameter	Relative humidity or dew / frost point	
Factory default scale	As per ordering code	
Output 2	Can be made to correspond to any parameter	
Factory default parameter	Temperature	
Factory default scale	As per ordering code	
Output 1 and Output 2		
Signal type	4...20 mA	0...20 mA 4... 20 mA 0... 1 V 0... 5 V 0... 10 V (user configurable)
Accuracy of analog output	±30 µA	±20 µA ±2 mV (0-1V) ±5 mV (0-10V)
User configurable scaling limits	-999.99 ... +9999.99 engineering units	
Maximum offset at bottom of signal range	no offset	0...1V signal range : 10 mV 0...5 V signal range : 50 mV 0...10 V signal range : 100 mV 0...20 mA signal range : 0.2 mA 4...20 mA signal range : no offset
Short circuit tolerant	Yes	
Maximum external load	500 Ω	500 Ω (current output)
Minimum external load	0 Ω	1 kΩ (0...1 V output) 5 kΩ (0...5 V output) 10 kΩ (0...10 V output) 0 Ω (current output)

Service connector	HF72	HF73
Interface type	UART (Universal Asynchronous Receiver Transmitter)	
Maximum service cable length	5 m (16.4 ft)	

General specifications	HF72	HF73
Probe material	Stainless steel V2A / 1.4305 / AISI 302	
Probe dust filter material	Depends on filter type	
Housing material	Aluminum die cast	
Housing protection grade	IP 65	
Physical dimensions	See Models	
Weight	Approx. 800 g (28.2 oz) + 140 g (4.9 oz) per probe extension unit	

E-M-HF7-V1_27	Rotronic AG Bassersdorf, Switzerland
Document code	Unit
HygroFlex HF7 Humidity Temperature Transmitters: User Guide	Instruction Manual
Document title	Document Type
	Page 25 of 27

Conformity with standards	HF72	HF73
CE / EMC immunity	EMC Directive 2004/108/EG: EN 61000-6-1: 2001, EN 61000-6-2: 2005 EN 61000-6-3: 2005, EN 61000-6-4: 2001 + A11	
Solder type	Lead free (RoHS directive)	
Fire protection class	Corresponds to UL94-HB	
FDA / GAMP directives	compatible	

Environmental limits	HF72	HF73
Operating limits at electronics	-40...185 °C (-10...60 °C with display), 0...100 %RH, non condensing – valid for survival only	
Temperature limits at probe	-100...+150 °C (valid for type N, D and A)	
Maximum humidity at sensor	100 %RH up to 80 °C (176 °F) 75 %RH at 100 °C (212 °F) 45 %RH at 125 °C (260 °F) 15 %RH at 150 °C (302 °F)	
Maximum air velocity at probe	40 m/s (7,870 ft /min) – depends on dust filter type	
Critical environments	Humidity sensor: as per DV04-14.0803.02 – Critical chemicals	

10.2 Dew point accuracy

The HF7 can be configured to calculate either the dew point or frost point based on the measurement of relative humidity and temperature. The accuracy of this conversion varies, depending on the humidity and temperature conditions as shown in the graph below:

DP/FP Accuracy

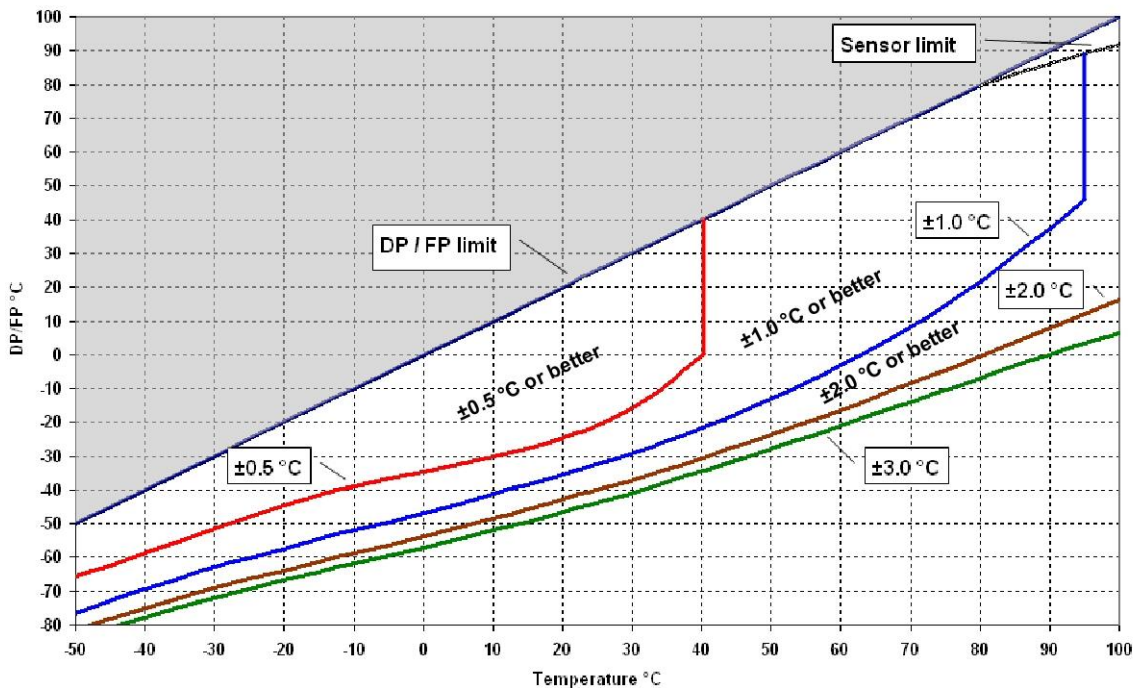

Example: at a temperature of 20 °C, a frost point value of -25 °C is measured with an accuracy of ± 0.5 °C or better.

E-M-HF7-V1_27 Document code	Rotronic AG Bassersdorf, Switzerland Unit
HygroFlex HF7 Humidity Temperature Transmitters: User Guide Document title	Instruction Manual Document Type Page 26 of 27

11 Accessories

For accessories and parts such as the HW4 configuration software, service cables, calibration accessories and spare dust filters, please see document **E-M-HC2-accessories**

12 Supporting documents

Document File Name	Contents
E-M-HC2-accessories	Accessories and parts for probes, indicators and transmitters
E-T-AC3000-DF-V1	AirChip 3000 Description and Main Functions
E-M-HW4v3-DIR	List of the HW4 manuals
E-M-HW4v3-Main	HW4 software version 3: General instructions and functions common to all devices
E-M-HW4v3-F2-007	HW4 software version 3: HF7 transmitter Device configuration and AirChip 3000 functions
E-M-HW4v3-A2-001	HW4 software version 3: Probe Adjustment function AirChip 3000 devices
E-M-HW4v3-DR-001	HW4 software version 3: Data Recording Function AirChip 3000 Devices
E-M-AC3000-CP	AirChip 3000 Communication Protocol Options
E-M-CalBasics	Temperature and humidity calibration basics
E-T-HumiDefs	Humidity Definitions Instructions for using the ROTRONIC humidity standards

Note: All document file names have an extension corresponding to the document release number (example of a first release: E-M-HW4v3-Main_10). This extension is not shown in the above table.

E-M-HF7-V1_27 Document code	Rotronic AG Bassersdorf, Switzerland Unit
HygroFlex HF7 Humidity Temperature Transmitters: User Guide Document title	Instruction Manual Document Type Page 27 of 27

13 Document releases

Doc. Release	Date	Notes
_20	Apr.11, 2009	Original release
_21	Nov. 6, 2009	Changed maximum operating temperature at electronics from 100°C to 85°C
_22	Mar. 2, 2010	Added the LC display option
_23	Jun. 20, 2010	Updated document for HW4 v.3
_24	Oct. 28, 2011	Updated this document regarding the model of service cable to be used with 2-wire and 3-wire models.
_25	Jan. 13, 2014	Changes for HF7 with firmware v3.0 Temperature specifications updated Power supply specifications updated Offset specifications updated Drawing of terminal block updated
_26	July 28, 2014	HF72 must be connected to protection ground.
_27	March 26, 2015	Accuracy of analog outputs added